

MAXair Premium Air Compressor part breakdown sheet - Single Stage Stationary Units C7380V1-CS4-MAP

REVISED 5/31/17

Item	Description	
1	Compressor w/ Flywheel	PV05AHP
2	Discharge Tube (2.5ft) ASSY	TU-2634-1A
3	Pressure Gauge	PGLF200-2.5BM1/4
4	Air Receiver (tank)	80VE24X48-Y
5	Drain Cock -Assembly	OSB WO DC ASSEMBLY
6	V-Belt	A71
7	Belt Guard	BG80GAL
8	Motor - 3 Phase, 208/230V	EM07.5-18-30
9	Wiring Harness	12/3-24-C4
10	Check Valve	P1010S-T
11	Combo Switch	CS-10/16A
12	Pulley - Motor	2MAL72
13	Unloader Tube	TU-1/4-CU
	**Fittings Required for TU-1/4CU	68-4A
14	Safety Valve	PSV1/4-200
15	Outlet Valve	BV1/4MXF
	Eagle Compressor Oil	EAOIL10

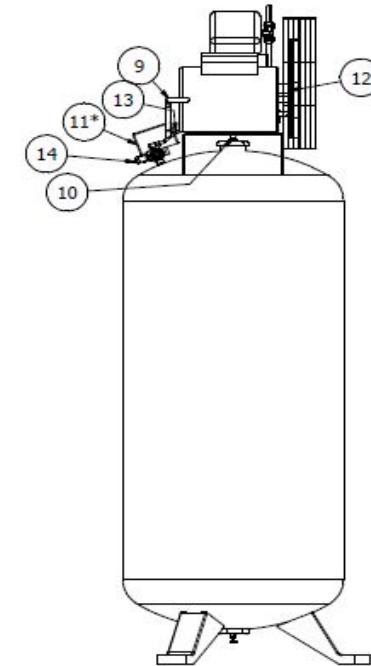
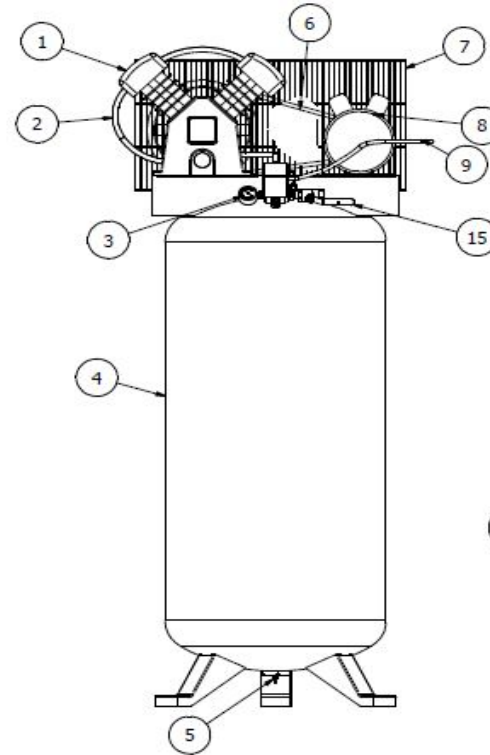

MAXair
PREMIUM

